

## Basic Compact Cost-effective Fast Charger

### Features

- Monolithic linear charger requires no inductors, external sense resistors or blocking diodes.
- A few external components are required
- 4.75V to 6.5V operating input voltage range.
- Programmable the charging current to achieve the fastest charging rate without the risk of overloading the adapter
- Thermal limit control of charging current prevents overheating
- Maximum of 1µA battery drain current
- Charging-current monitor output for system supervision of charging status
- TQFN-16, RoHS compliant lead-free package

### Applications

- Cellular phones and smart phones
- PDAs Portable Media Viewers
- Digital Still Camera
- Cradle Chargers

### Product Description

The CM9100 is an integrated linear-mode charger for single-cell, Lithium-ion batteries. It designed for compact and cost-sensitive handheld devices. It provides programming charge current, charge status indicator, high accuracy fast charge current and automatic charge voltage regulation. It requires no external blocking diodes or current sense resistors and needs only one external resistor to program the charging current.

The CM9100 provides Precharge, Fast-charge (constant-current), and Termination (constant-voltage) charging modes. The Precharge/Termination currents are preset to 10/5% of the Fast-charge current level. A host system can monitor the actual charge current at the ISET pin.

When the chip temperature reach 140°C, the CM9100 goes into a latched shutdown mode stop charging until the chip temperature is below 140°C will gradually charge and 105°C resume fast charge. When the adapter is not present, the CM9100 draws less than 1µA of drain current from the battery in ultra low power sleep mode.

The CM9100 is packaged in a miniature 16-pin TQFN. It can operate over the ambient temperature range of -40°C to 85°C.

### Typical Application

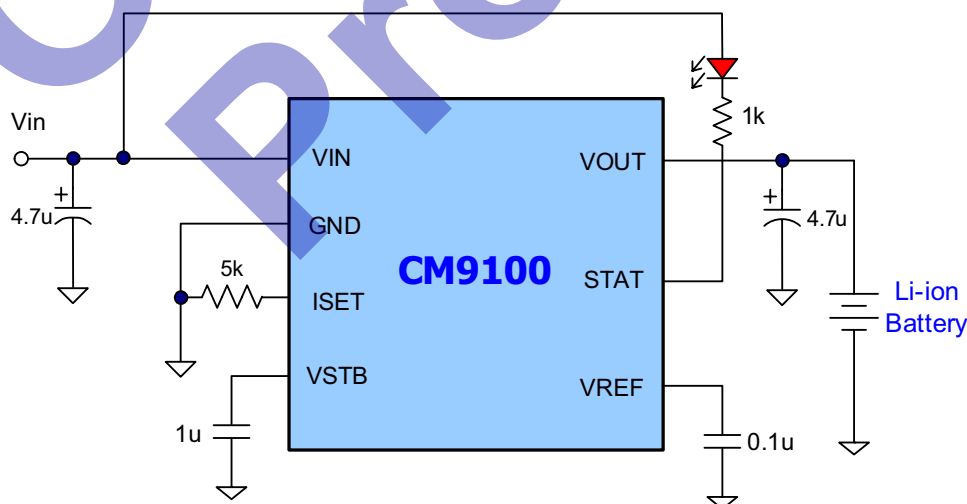

## Package Pinout

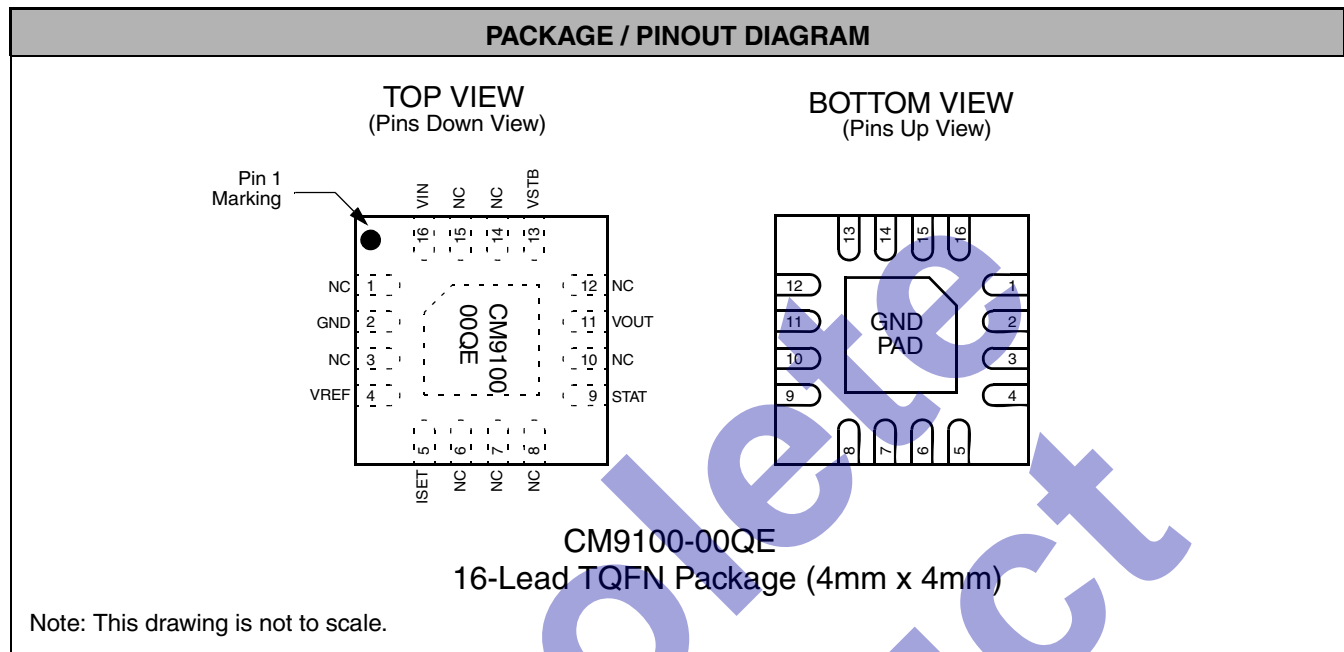
**PIN DESCRIPTIONS**

LEAD(s)	NAME	DESCRIPTION
1	NC	No connect.
2	GND	Ground pin.
3	NC	No connect.
4	VREF	4.2V, 2mA reference output pin.
5	ISET	Pin to set the maximum charging current in the Fast charge (CC) mode. Also, reflects actual charging current. A resistor between this pin and ground sets the charge current, $I_{CH}$ : $R_{ISET} = \frac{1000 \times 2.5V}{I_{CC}}$
6	NC	No connect.
7	NC	No connect.
8	NC	No connect.
9	STAT	Charging status indicator pin (open-drain output).
10	NC	No connect.
11	VOUT	Charger output pin
12	NC	No connect.
13	VSTB	4.2V output pin, connect a cap to ground to increase stability.
14	NC	No connect.

**Pin Descriptions (cont'd)**

PIN DESCRIPTIONS		
15	NC	No connect.
16	VIN	Positive input supply voltage pin, which powers the charger.

**Ordering Information**

PART NUMBERING INFORMATION			
Pins	Package	Lead Free Finish	
		Ordering Part Number <sup>1</sup>	Part Marking
16	TQFN	CM9100-00QE	CM9100 00QE

Note 1: Parts are shipped in Tape & Reel form unless otherwise specified.

**Specifications**

ABSOLUTE MAXIMUM RATINGS		
PARAMETER	RATING	UNITS
ESD Protection (HBM)	±2	kV
V <sub>IN</sub> to GND	[GND - 0.3] to +6.5	V
Pin Voltages V <sub>OUT</sub> , V <sub>REF</sub> , V <sub>STB</sub> to GND	[GND - 0.3] to +6.5	V
I <sub>SET</sub> , STAT to GND	[GND - 0.3] to +6.5	V
Storage Temperature Range	-65 to +150	°C
Operating Temperature Range (Ambient)	-40 to +85	°C
Lead Temperature (Soldering, 10sec)	300	°C

**ELECTRICAL OPERATING CHARACTERISTICS (SEE NOTE 1)**

SYMBOL	PARAMETER	CONDITIONS	MIN	TYP	MAX	UNITS
V <sub>IN</sub>	VIN Supply Voltage		4.75		6.5	V
I <sub>Q</sub>	Quiescent Current	Charging modes, excluding current to ISET and STAT pins. All outputs are at no load.		2		mA
I <sub>DR</sub>	Battery Drain Current	V <sub>IN</sub> = 0V (100Ω - resistor to ground), V <sub>BAT</sub> = 4.2V		0.5	1	μA
<b>Charger Function</b>						
I <sub>PR</sub>	Precharge Mode Current	V <sub>OUT</sub> < 3.2V	0.85 x I <sub>PR</sub>	$I_{PR} = \frac{250}{R_{SET(k\Omega)}}$	1.14 x I <sub>PR</sub>	mA
V <sub>CC</sub>	CC Mode Voltage Threshold		3.20	3.30	3.40	V

**Specifications (cont'd)**

<b>ELECTRICAL OPERATING CHARACTERISTICS (SEE NOTE 1)</b>						
<b>SYMBOL</b>	<b>PARAMETER</b>	<b>CONDITIONS</b>	<b>MIN</b>	<b>TYP</b>	<b>MAX</b>	<b>UNITS</b>
$I_{CC}$	CC Mode Charging Current	$V_{OUT} > 3.5V$	$0.92 \times I_{CC}$	$I_{CC} = \frac{2500}{R_{SET(k\Omega)}}$	$1.08 \times I_{CC}$	mA
$V_{CV}$	CV Mode Voltage Threshold		4.190	4.200	4.210	V
$I_{TERM}$	Charge Termination Current	$V_{OUT} > 4.190V$	$0.8 \times I_{TERM}$	$I_{TERM} = \frac{100}{R_{SET(k\Omega)}}$	$1.2 \times I_{TERM}$	mA
$V_{RCH}$	Recharge Mode Threshold		4.090	4.100	4.110	V
CT	Constant-temperature Mode, Limit	(Note 2)	95	105	125	C
OTP <sub>LIMIT</sub>	Over-temperature Protection, Limit	(Note 3)	130	140	150	C
$I_{LIMIT}$	Over-current Charging (OCP), Limit	(Note 4)	0.9	1.0	1.1	A
$R_{DSON}$	$R_{DSON}$ of Charger MOSFET	$I_{CC} = 500mA$	100	120	150	mΩ
<b>VREF</b>						
$V_{REF}$	Regulated Voltage $V_{REF}$	$I_{REF} < 1mA$	4.190	4.200	4.210	V
<b>VSTB</b>						
$V_{STB}$	Regulated Voltage $V_{STB}$		4.100	4.200	4.300	V
<b>Control Function</b>						
$V_{STAT}$	STAT (Open Drain) Output Low Voltage	$I_{SINK} = 5mA$ $I_{SINK} = 20mA$			0.1 0.5	V V

Note 1:  $V_{IN} = 5.0V$ . All outputs are on.  $T_A = 25^\circ C$  unless otherwise specified.

Note 2: When chip temperature reaches  $105^\circ C$ , the IC's internal thermal limit will maintain this temperature by decreasing the programmed charge current

Note 3: When chip temperature reaches  $140^\circ C$ , the IC goes into a latched shutdown mode. It stops charging, stops supplying  $V_{OUT}$ . To resume the charging function, a toggle of  $V_{IN}$  is required.

Note 4: When charging current reaches 1.2A, the IC goes into shutdown, latched mode only toggled  $V_{IN}$  could resume the function.

Typical Performance Curves

**Charging Algorithm**  
 Battery Emulator, C<sub>battery</sub> = 30 mF  
 R<sub>ISET</sub> = 5 kΩ

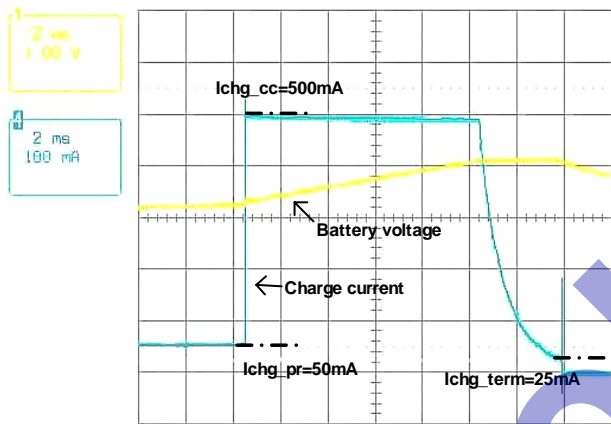

Time (2 ms/div)  
**Battery Current Thresholds**

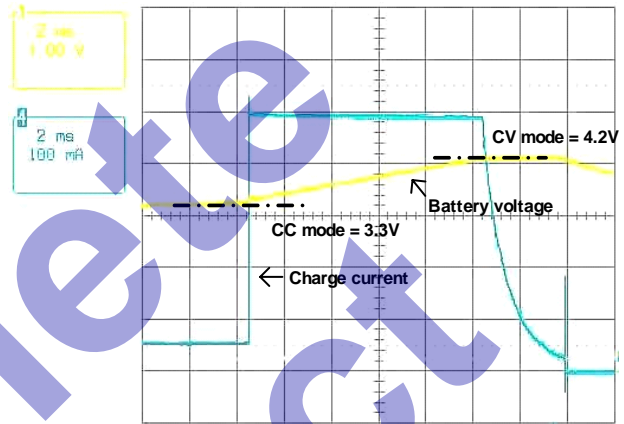

Time (2 ms/div)  
**Battery Voltage Thresholds**

Functional Block Diagram

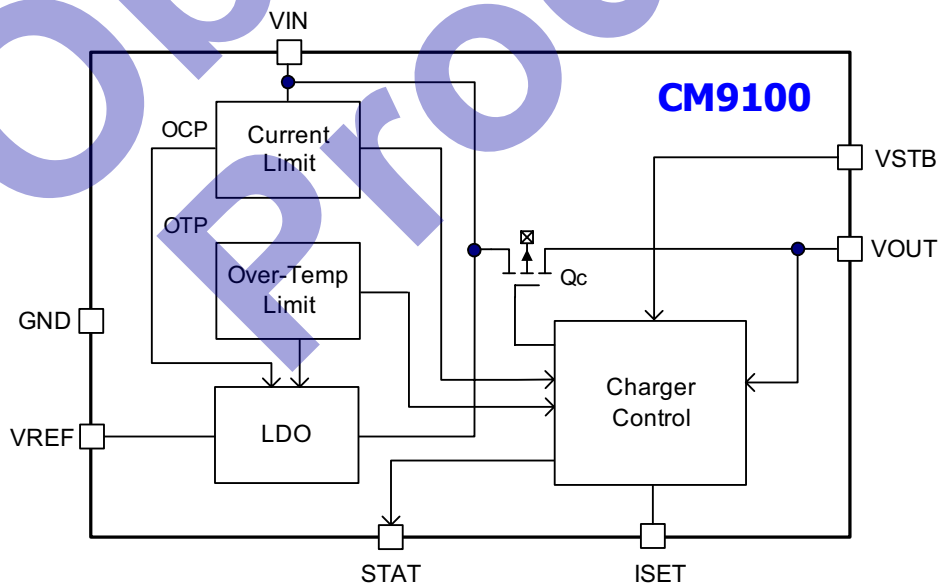

**Flow Chart**

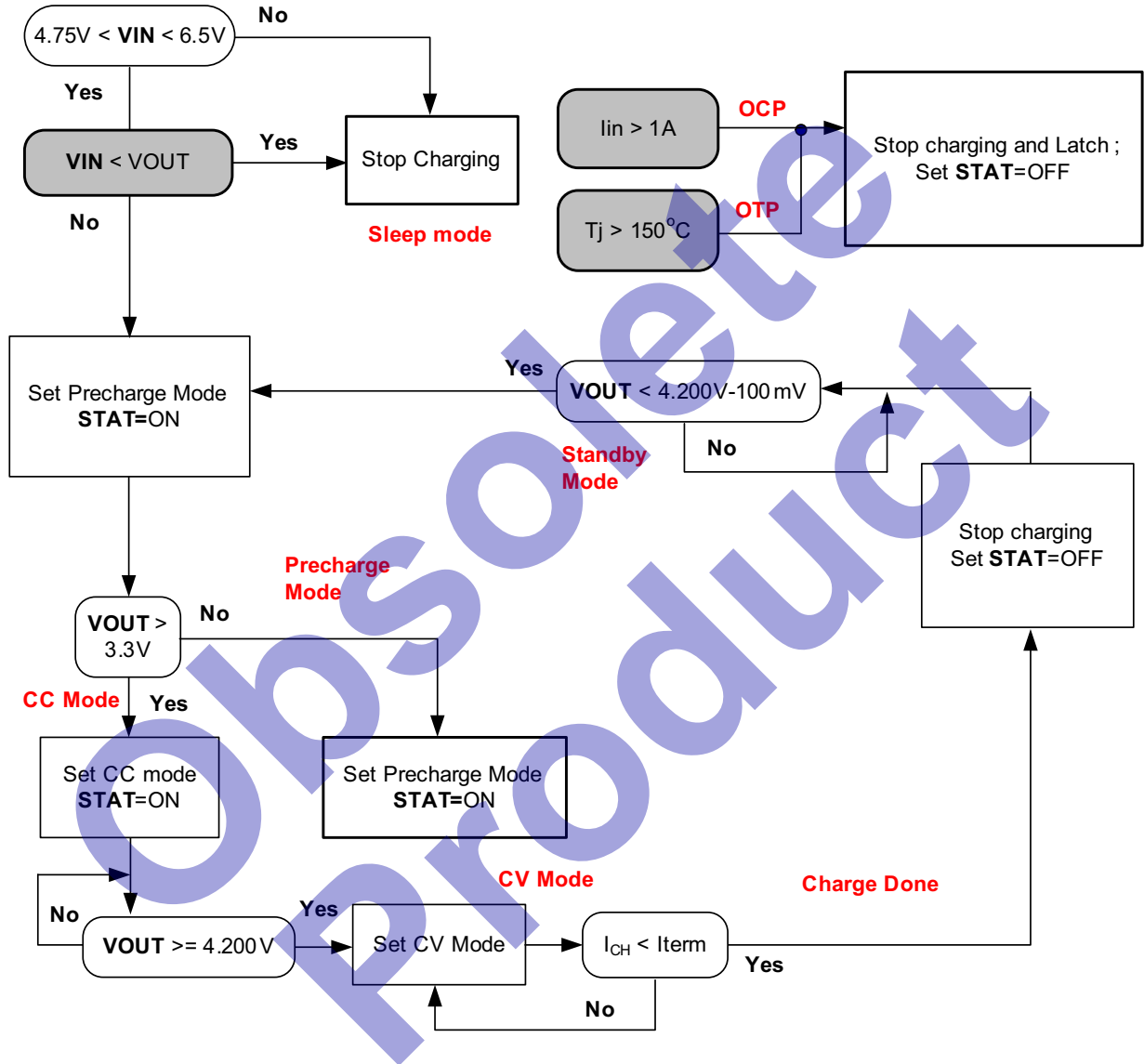

## Application Information

The CM9100 is an integrated charger with a charging profile tailored for single-cell graphite electrode (anode) Li-ion batteries. With single resistor charge current programming, the CM9100 can provide charge currents up to 1000mA, or limited to 100mA/500mA for USB input applications.

The charger features the three modes required for a safe and reliable Li-ion charging profile; Precharge, Fast-charge, and Termination charge. Extensive safety features include voltage and current monitoring. A status indicator provides charge state information.

### Linear Charger vs. Switching Charger

A Li-ion battery charger can be either a switching or a linear regulator. A switching regulator type charger achieves higher efficiency, typical 90% or better, over a wide range of load and line conditions and generally offers a faster charging speed. However, a switching charger requires an external power inductor, which occupies substantial PC board space with added weight. Another issue with switching regulators is the switching noise and the potential EMI it generates.

In contrast, The CM9100 linear charger is implemented with a single IC, without the use of an inductor. The CM9100 provides a complete Li-ion charging control system, with integrated power MOSFETs and several important features, requiring just a few external resistors and capacitors for a compact system design. A sophisticated thermal management system addresses the concerns commonly associated with linear chargers.

### Input

When using a constant-voltage, 5VDC nominal, AC adapter, the semi-regulated voltage to the charger, after accounting for the conduction losses through the power cord and connector contacts, is a voltage in the range of 5.0V to 6.0V.

The USB standard specifies a 5.0V +/-5% bus voltage, capable of 500mA (High Power peripheral configuration) of current. When using a USB input, the charging current must be limited to <500mA, which is set with the  $R_{SET}$  resistor. In a system that requires 100mA starting current until told by the host controller to go into High Power mode, the circuit in [Figure 1](#) can be used. Q1 can be the output of the controller.

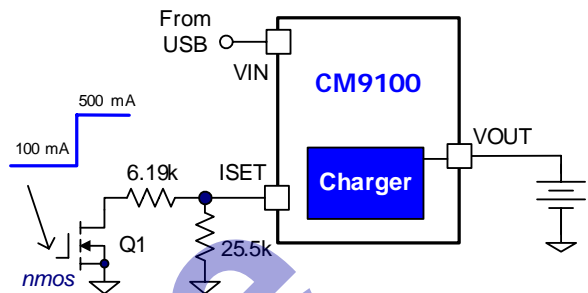

Figure 1. USB Input Circuit

### Charging Li-ion Batteries

Once the CM9100 detects the presence of a valid AC adapter, and checks that the battery voltage at  $V_{OUT}$  is less than  $V_{IN}$ , it is ready to charge the Li-ion battery.

If the battery voltage is deeply discharged (less than 3.2V), the CM9100 will start in the Precharge mode, charging at 10% of the programmed Fast-charge current level. See [Figure 2](#). While the battery is charging, the status pins will be set to  $STAT=0$ . The Precharge current will gradually bring the battery voltage to above 3.2V.

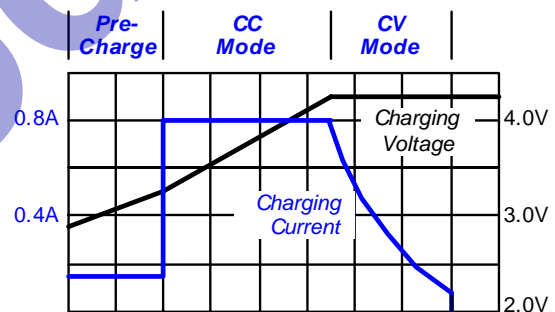

Figure 2. Typical Li-ion Battery Charging Process

Once the battery voltage exceeds the 3.3V threshold, the CM9100 enters the Fast-charge, constant-current (CC) mode. The status pins will be set to  $STAT=0$ . During the CC mode, the charging current is limited by the maximum charging current, programmed with a single resistor between  $I_{SET}$  and ground,  $R_{ISET}$ :

$$I_{FASTCHG(max)} = \frac{2.5V \times 1000}{R_{ISET}}$$

## Application Information (cont'd)

Most battery manufacturers recommend an optimal charging current for their battery. This is typically a time ratio related to the battery capacity, with a value of .7C to 1C, once the battery is above the Precharge voltage level. For example, a 750mAh capacity battery with recommended charge of .7C could have  $I_{CC}$  set for about 525mA, with  $R_{ISET}$  equal to 4.75k $\Omega$ , 1%.

The actual Fast-charge current might be further limited by either the maximum chip temperature limit, determined by the power dissipation on the CM9100 chip, the ambient temperature ( $T_A$ ), and the junction-to-ambient thermal resistance,  $R_{th(JA)}$ .

When the battery terminal voltage, sensed at  $V_{OUT}$ , approaches 4.2V, the CM9100 enters the Termination (CV) mode. The charger then regulates its output voltage at 4.20V, and the charging current gradually decreases as the battery's internal voltage,  $V_{OC}$ , rises toward 4.2V. The actual charging current is now determined by the differential voltage (4.20V -  $V_{OC}$ ) and the internal impedance,  $R_{internal}$ , of the Li-ion battery-pack.

The CM9100 ends the charging process when charging current drops below 5% of the Fast-charge (CC) mode current level. Once terminated, the charge current is completely stopped and no trickle charge is applied. Trickle (or float) charging is not required due to the minimal self-discharge of the Li-ion cells, and they are unable to absorb overcharge, which causes plating of metallic lithium and shortens the life of the battery.

Following the Termination mode, the charger will enter the Standby mode. The status pin will be set to  $STAT = V_{IN}$ .

If the wall adapter is left plugged-in while in the Standby mode, the charger will continue to monitor the battery voltage. It automatically re-charges the battery when the battery voltage drops below the re-charge threshold. When the adapter is removed, the CM9100 will drain less than 1 $\mu$ A from the battery.

## Charging Current Foldback in the Over-temperature Condition

A limitation of linear chargers is that they are vulnerable to over-temperature conditions. The CM9100 will throttle down the charging current when the chip junction temperature reaches 105 $^{\circ}$ C (with 10 $^{\circ}$ C of hysteresis).

This protects the charger IC and its nearby external components from excessive temperature.

The Charger IC junction temperature is determined by several factors in the following equation:

$$T_J = T_A + PD + R_{th(JA)} \quad (1)$$

The  $R_{th(JA)}$  is usually determined by the IC package and the thermal resistance between the package and the PC board. In particular, a SMD IC package relies on the underlying PC board copper to move the heat away from the junction. The key to reducing the thermal resistance between the IC package and the underlying PC board is using a large copper (Cu) area for solder attach and a large ground plane underneath the charger IC to conduct the heat away.

The power dissipation (PD in equation 1) of a linear charger is the product of input-output voltage differential and output current.

$$PD = (V_{IN} - V_{OUT}) \times I_{OUT}$$

Highest power dissipation occurs when the battery at its lowest level (3.2V), when it just starts in the Fast-charge (CC) mode. Assuming  $V_{IN} = 5.0V$ ,  $V_{BAT} = 3.2V$ ,  $I_{CC} = 1A$ , the  $PD = (5V - 3.2V) \times 1A = 1.8W$ . Assuming  $R_{th(JA)} = 50^{\circ}C/W$ , then  $\Delta T = 1.8W \times 50^{\circ}C/W = 90^{\circ}C$ . If the ambient temperature ( $T_A$ ) is 35 $^{\circ}$ C, then the junction temperature ( $T_J$ ) could reach 125 $^{\circ}$ C without over-temperature current foldback.

With over-temperature (OT) current foldback, the CM9100 will throttle down the charging current, allowing the junction temperature will reach steady-state equilibrium of 105 $^{\circ}$ C, which translates into 1.4W of power dissipation, or 0.78A of charge current. As the battery voltage rises during charging, the allowable PD dissipation is increased. When the battery voltage reaches 3.6V, a full 1.0A of charging current is allowed.

## OTP and OCP

In addition to chip temperature regulation at 105 $^{\circ}$ C, the CM9100 provides absolute over-temperature shutdown protection. In the case of a malfunctioning charger control, high ambient temperature or an unexpectedly high IC thermal resistance,  $R_{th(JA)}$  (for example, due to faulty soldering of the charger IC chip). The CM9100

## Application Information (cont'd)

provides an absolute OTP shutdown at junction temperature of 150°C.

### Charging status

CM9100 provides a charging status indicator pin: STAT. This is an open-drain output, which can drive an LED directly, with up to 20mA of current sinking capability. Alternatively, the system supervisory microprocessor can monitor the battery charging status by interfacing with this pin, using a 100kΩ pull-up resistor. See [Table 1](#).

CHARGE STATUS	STAT
Precharge in progress	Low -
Fast-charge in progress	Low -
Charge completed	High -
Charge suspended (OTP, OCP)	High -

**Table 1: Charge Status for STAT**

### Charging Control by the Host System

The CM9100 allows a host-system to take active control of the charging process by providing actual charging current monitoring via the 1000:1 current mirror on R<sub>ISET</sub>. This is especially useful for the system's direct control of the Termination threshold (preset to 5% of CC mode level).

### Mode Summary

**Precharge mode** is the typical charge starting mode for pre-conditioning a deeply discharged battery (<3.3V). A constant current of 10% of the programmed Fast-charge current is applied to raise the voltage safely above 3.3V.

**Fast-charge mode** is the constant current charging mode that applies most of the battery charge. A programmed constant current is applied to bring the battery voltage to 4.2V.

**Termination mode** is the final charging mode, where a constant voltage of 4.2V is applied to the battery until the charge current drops below 5% or the programmed Fast-charge current.

**Standby mode** is entered after a successful Termination mode and charging is done. Charging stops. In this mode, the battery is monitored, and when its voltage

drops below the re-charge threshold, a new charge cycle begins.

**Shutdown mode** is triggered by a charging fault. These include, Input current that exceeds 2.4A (OCP), the IC junction temperature exceeds 150°C (OTP). Charging stops.

**Sleep mode** is entered when the Adapter is removed (or is the wrong voltage). Charging stops. In this mode, the CM9100 draws less than 1μA of current from the battery.

### Component Selection

The constant voltage AC Adapter must be selected carefully to minimize power losses and heat dissipation in the charger. The input supply should be between 5.0V and 6.0V. The lowest allowable input voltage will minimize heat dissipation and simplify the thermal design.

### Layout Considerations

Because the internal thermal foldback circuit will limit the current when the IC reaches 105°C it is important to keep a good thermal interface between the IC and the PC board. It is critical that the exposed metal on the backside of the CM9100 be soldered to the PCB ground. The Cu pad should be large and thick enough to provide good thermal spreading. Thermal vias to other Cu layers provide improved thermal performance.

V<sub>IN</sub> and V<sub>OUT</sub> are high current paths and the traces should be sized appropriately for the maximum current to avoid voltage drops.

Typical Evaluation Circuit

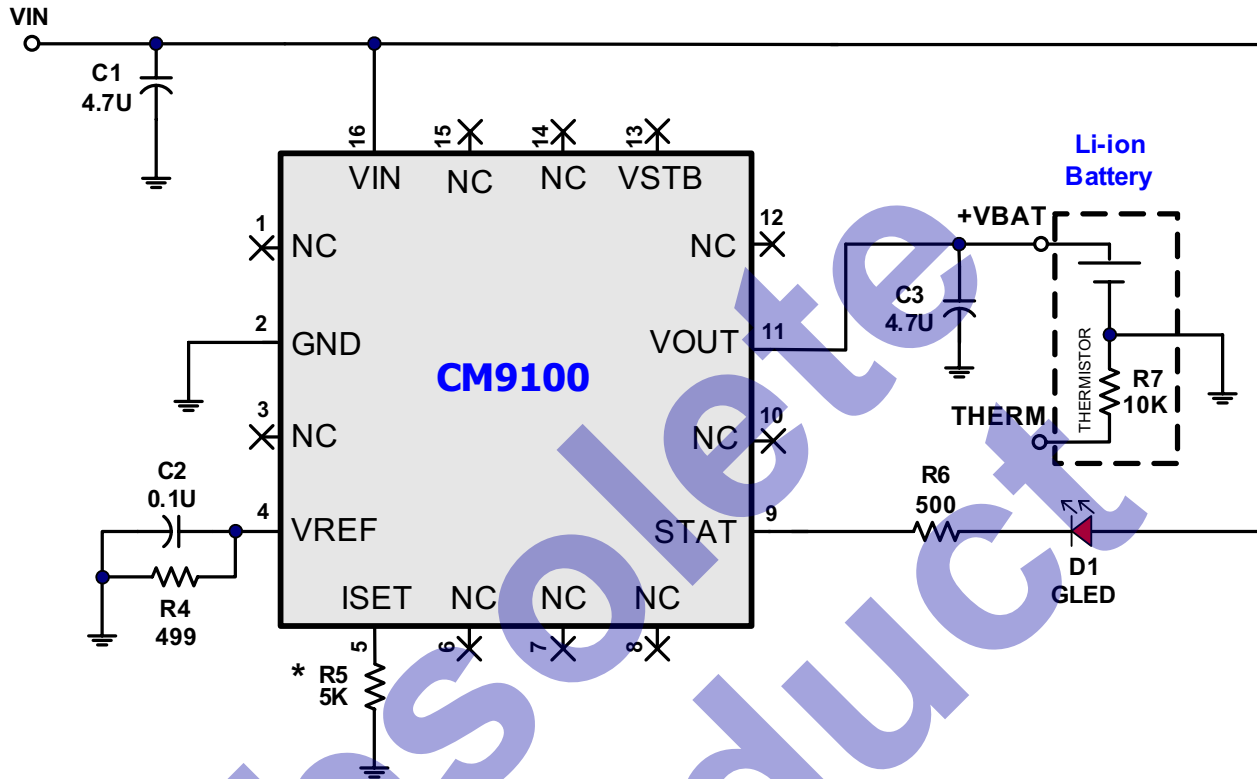

Observed Products

## Mechanical Details

### TQFN-16 Mechanical Specifications

The CM9100-00QE is supplied in a 16-lead, 4.0mm x 4.0mm TQFN package. Dimensions are presented below.

For complete information on the TQFN16, see the California Micro Devices TQFN Package Information document.

PACKAGE DIMENSIONS						
Package	TQFN-16 (4x4)					
Leads	16					
Dim.	Millimeters			Inches		
	Min	Nom	Max	Min	Nom	Max
A	0.07	0.75	0.80	0.28	0.030	0.031
A1	0.00		0.05	0.00		0.002
A3	0.20 REF			.008		
b	0.25	0.30	0.35	0.010	0.012	0.014
D	3.90	4.00	4.10	0.154	0.157	0.161
D1	1.95 REF			0.077		
D2	2.00	2.10	2.20	0.079	0.083	0.087
E	3.90	4.00	4.10	0.154	0.157	0.161
E1	1.95 REF			0.077		
E2	2.00	2.10	2.20	0.079	0.083	0.087
e	0.65 TYP.			0.026		
L	0.45	0.55	0.65	0.018	0.022	0.026
# per tape and reel	3000 pieces					
Controlling dimension: millimeters						

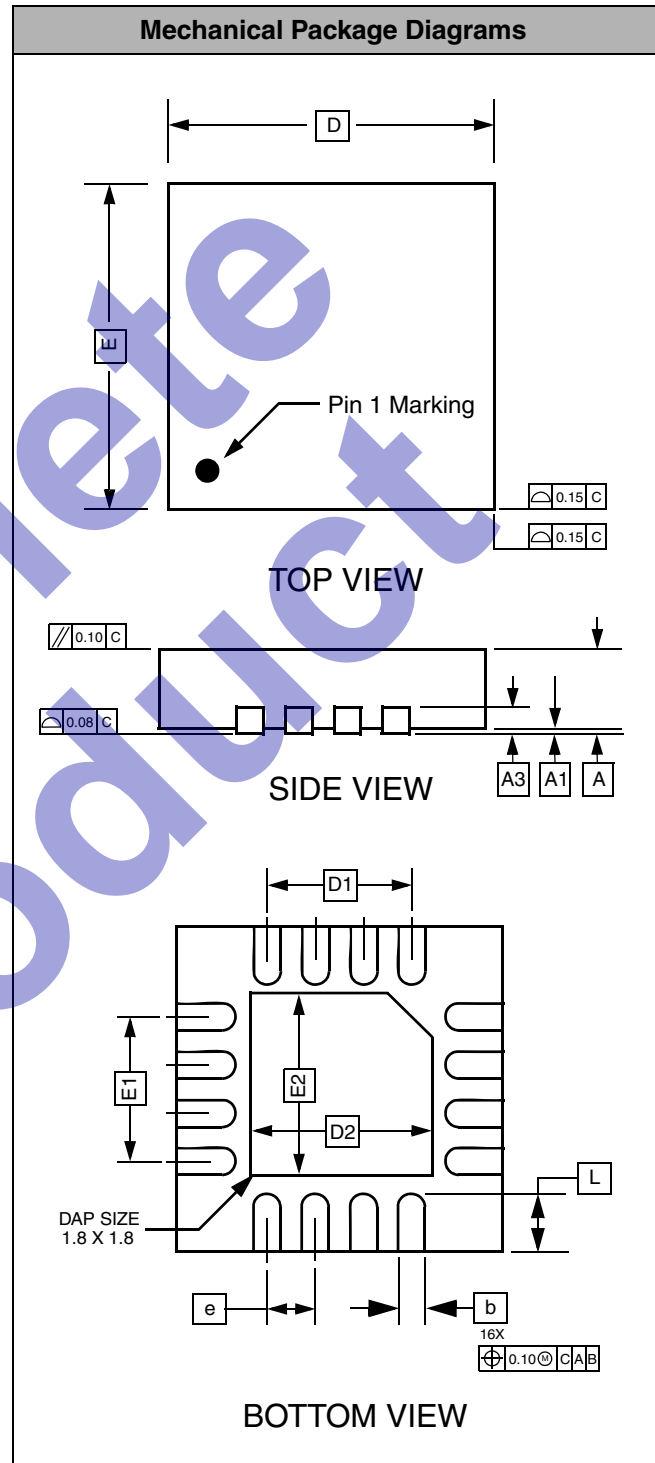

Package Dimensions for 16-Lead TQFN