

2.0 Amp Tri-Mode Low Dropout CMOS Regulator

Features

- Operates as an adjustable output or a fixed output regulator with 2 output voltage options
- 1.8V or 2.5V fixed output voltage versions
- 360mV dropout at 2.0A load current
- Operates from 2.2V to 5.5V input supply
- Low Ground current (350µA at 2.0A Load)
- Stable with low ESR ceramic output capacitor
- Current limit protection
- Thermal overload protection
- Reverse voltage protection
- Thermally enhanced 8-lead SOIC or 3-lead TO-263 package
- Lead-free versions available

Applications

- Low voltage "Core" processors
- Graphics cards
- Gigabit NIC cards
- PC motherboards
- Notebook computers

Product Description

The CM3065 family of very low dropout regulators offers both fixed/adjustable-output and fixed-output operation capable of delivering up to 2A of current. The CM3065 devices are fully protected, offering overload current limiting, short circuit protection, high temperature thermal shutdown, and reverse voltage protection to minimize reverse current flow into the output pin.

The CM3065-xxSA/SF (8-lead, SOIC packaged) devices operate in either adjustable or fixed output modes. When the ADJ input is grounded, the regulator operates as a fixed output voltage device at the specified output voltage. When the ADJ input is connected to an external resistor network the device operates as an adjustable regulator. The ADJ input can also be tied directly to the OUT pin which configures the CM3065 as a 1.2V regulator. The CM3065-xxSA/SF devices feature an Enable control input (EN), which when set low, disables the device to a low quiescent current mode.

The CM3065-xxTO/TN (TO-263 packaged) versions operate as higher power, fixed output voltage devices and are available with 1.8V or 2.5V outputs voltages only.

The CM3065 is available in a space saving, 8-lead power SOIC which has been thermally enhanced with an integral leadframe to ensure maximum junction to ambient power dissipation, or a 3-lead TO-263 package. Both packages are offered with optional lead-free finishing.

Typical Application Circuit

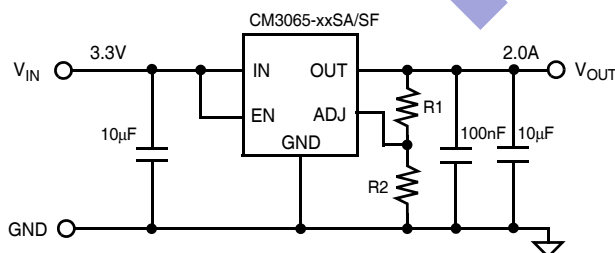

Note 1: EN pin is internally tied to V_{IN} on CM3065-xxTO/TN devices
 Note 2: ADJ pin is internally tied to GND on CM3065-xxTO/TN devices.

Simplified Electrical Schematic

(See notes below for TO-263 devices.)

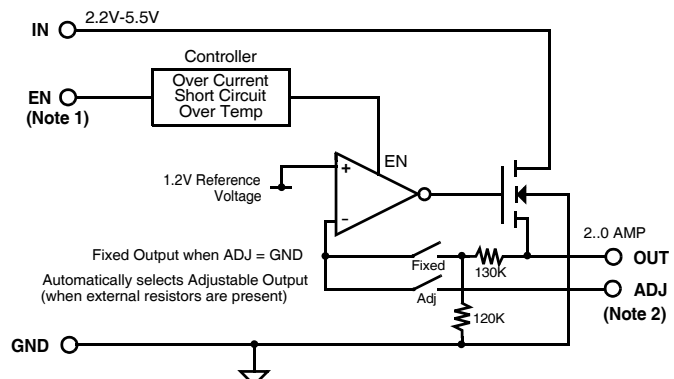

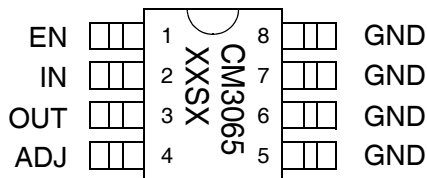
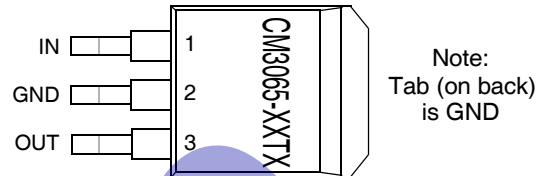
PACKAGE / PINOUT DIAGRAM
TOP VIEW

8-lead Power SOIC
TOP VIEW

3-lead TO-263

Note: These drawings are not to scale.

PIN DESCRIPTIONS

TO-263 LEAD(S)	SOIC-8 LEAD(S)	NAME	DESCRIPTION
1	2	IN	Positive input voltage for the regulator. If this input pin is greater than 2 inches from the main input filter, a 10 μ F ceramic capacitor is recommended for adequate filtering.
2, TAB	5-8	GND	The negative reference for all voltages. Also functions as a thermal path for heat dissipation.
3	3	OUT	The regulated voltage output. An output capacitor of 10 μ F is recommended to minimize any transient load disturbances under normal operating conditions. Additional output capacitance can be used to further improve transient load response.
---	1	EN	Enable/shutdown input. When EN is asserted high ($V_{EN} \geq 1.2V$), the regulator is enabled. When EN is asserted low ($V_{EN} \leq 0.4V$), the regulator is shut down.
---	4	ADJ	Feedback input. When ADJ is grounded, the device enters fixed voltage mode. When ADJ is connected to an external resistor network, the device operates as an adjustable regulator. The Adjust pin can also be tied directly to the OUT pin which configures the CM3065 as a 1.2V regulator.

Ordering Information
PART NUMBERING INFORMATION

LEADS/ PINS	Output Voltage	Package	Standard Finish		Lead-free Finish	
			Ordering Part Number ¹	Part Marking	Ordering Part Number ¹	Part Marking
8	2.5	SOIC-8	CM3065-25SA	CM3065-25SA	CM3065-25SF	CM3065-25SF
8	1.8	SOIC-8	CM3065-18SA	CM3065-18SA	CM3065-18SF	CM3065-18SF
3	2.5	TO-263	CM3065-25TO	CM3065-25TO	CM3065-25TN	CM3065-25TN
3	1.8	TO-263	CM3065-18TO	CM3065-18TO	CM3065-18TN	CM3065-18TN

Note 1: TO-263 packaged parts are fixed output.

Note 2: Parts are shipped in Tape & Reel form unless otherwise specified.

Specifications

ABSOLUTE MAXIMUM RATINGS		
PARAMETER	RATING	UNITS
ESD Protection (HBM)	±2000	V
Pin Voltages IN, OUT, ADJ, EN	[GND - 0.4] to +6.0	V
Storage Temperature Range	-40 to +150	°C
Operating Temperature Range Ambient Junction	-40 to +85 -40 to +150	°C °C
Power Dissipation (See note 1)	Internally Limited	W

Note 1: The SOIC package used is thermally enhanced through the use of a fused integral leadframe. The power rating is based on a printed circuit board heat spreading capability equivalent to 2 square inches of copper connected to the GND pins. Typical multi-layer boards using power plane construction will provide this heat spreading ability without the need for additional dedicated copper area. (Please consult with factory for thermal evaluation assistance)

STANDARD OPERATING CONDITIONS		
PARAMETER	VALUE	UNITS
V _{IN}	2.2 to 5.5	V
Ambient Operating Temperature Range	-40 to +85	°C
Load Current	0 to 2000	mA
C _{OUT}	10 ±20%	µF

ELECTRICAL OPERATING CHARACTERISTICS (SEE NOTE 1)

SYMBOL	PARAMETER	CONDITIONS	MIN	TYP	MAX	UNITS
V_{OUT}	Regulator Output Voltage	$0mA < I_{LOAD} < 2.0A$, $V_{IN} \geq [V_{OUT} + 0.8V]$, $V_{ADJ}=0V$				
	CM3065-25		2.45	2.50	2.55	V
	CM3065-18		1.764	1.80	1.836	V
I_{LIM}	Overload Current Limit	$V_{OUT} > 1.2V$	2.2	3.0	3.8	A
I_{SC}	Short Circuit Current Limit	$V_{OUT} < 0.2V$	0.5	1.2	1.8	A
$V_{R\,LOAD}$	Load Regulation	$V_{IN}=[V_{OUT} + 0.8V]$, $100mA \leq I_{LOAD} \leq 1.5A$		0.2	0.4	%
		$V_{IN}=[V_{OUT} + 0.8V]$, $100mA \leq I_{LOAD} \leq 2.0A$		0.3	0.6	%
$V_{R\,LINE}$	Line Regulation	$I_{LOAD} = 5mA$; $3.0V \leq V_{IN} \leq 5.0V$		0.2	0.4	%
$V_{DROPOUT}$	Dropout Voltage	$I_{LOAD} = 100mA$		18	45	mV
		$I_{LOAD} = 1.0A$		180	450	mV
		$I_{LOAD} = 1.5A$		270	600	mV
		$I_{LOAD} = 2.0A$		360	700	mV
I_{GND}	Ground Current	Regulator Disabled ($EN=GND$); $V_{IN}=3.3V$; Note 2		5	30	μA
		Regulator Enabled ($EN=V_{IN}=[V_{OUT} + 0.8V]$); $I_{LOAD}=0mA$; Note 2		325	500	μA
		Regulator Enabled ($EN=V_{IN}=[V_{OUT} + 0.8V]$); $I_{LOAD}=1.5A$; Note 2		330	550	μA
		Regulator Enabled ($EN=V_{IN}=[V_{OUT} + 0.8V]$); $I_{LOAD}=2.0A$; Note 2		350	600	μA
I_{ROUT}	Output Reverse Leakage	$V_{OUT}=3.3V$; $V_{IN} = 0V$		30	100	μA
$T_{DISABLE}$	Shutdown Temperature			160		$^{\circ}C$
T_{HYST}	Thermal Hysteresis			25		$^{\circ}C$

Enable Pin Input (CM3065-xxSA only)

V_{TH_EN}	EN Input Threshold Voltage	Note 2	0.4	-	1.2	V
I_{EN}	EN Input Leakage Current	$0V < V_{EN} < 5.5V$; Note 2		0.1	5	μA

Adjust Pin Input (output set by external resistors, CM3065-xxSA only)

V_{TH_ADJ}	ADJ Input Threshold Voltage	Note 2	0.1	0.2	0.3	V
I_{EN}	ADJ Input Leakage Current	$V_{ADJ} > 1.1V$; Note 2		0.1	1	μA

Note 1: Operating Characteristics are over Standard Operating Conditions unless otherwise specified.

Note 2: Applies for CM3065-xxSA devices only.

Mechanical Details

The CM3065 is available in either an 8-lead SOIC or a 3-lead TO-263 package.

SOIC-8 Mechanical Specifications

Dimensions for CM3065 devices supplied in an 8-lead SOIC package are presented below.

For complete information on the SOIC-8 package, see the California Micro Devices SOIC Package Information document.

PACKAGE DIMENSIONS				
Package	SOIC			
Leads	8			
Dimensions	Millimeters		Inches	
	Min	Max	Min	Max
A	1.35	1.75	0.053	0.069
A ₁	0.10	0.25	0.004	0.010
B	0.33	0.51	0.013	0.020
C	0.19	0.25	0.007	0.010
D	4.80	5.00	0.189	0.197
E	3.80	4.19	0.150	0.165
e	1.27 BSC		0.050 BSC	
H	5.80	6.20	0.228	0.244
L	0.40	1.27	0.016	0.050
# per tube	100 pieces*			
# per tape and reel	2500 pieces			
Controlling dimension: inches				

* This is an approximate number which may vary.

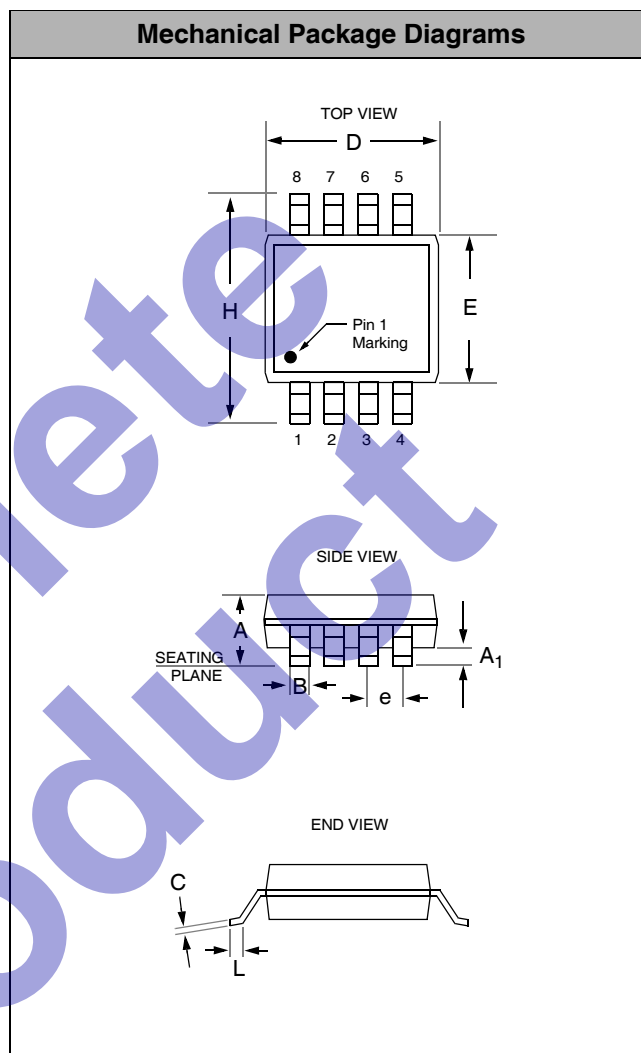

Package Dimensions for SOIC-8

Mechanical Details (cont'd)

TO-263-3 Mechanical Specifications

Dimensions for CM3065 devices supplied in a 3-lead TO-263 package are presented below.

For complete information on the TO-263-3 package, see the California Micro Devices TO-263 Package Information document.

PACKAGE DIMENSIONS				
Package	TO-263			
Leads	3			
Dimensions	Millimeters		Inches	
	Min	Max	Min	Max
A	4.06	4.57	0.160	0.190
b	0.508	0.990	0.020	0.039
b ₂	1.14	1.40	0.045	0.055
c	0.457	0.737	0.018	0.029
c ₂	1.14	1.40	0.045	0.055
D	8.64	9.65	0.340	0.380
D ₁	8.00	---	0.315	---
E	9.65	10.29	0.380	0.405
E ₁	6.22	---	0.245	---
e	2.54 BSC		0.100 BSC	
L	14.60	15.87	0.575	0.625
L ₁	2.29	2.79	0.090	0.110
L ₂	---	1.40	---	0.055
L ₄	0.254 BSC		0.010 BSC	
# per tube	100 pieces*			
# per tape and reel	2500 pieces			
Controlling dimension: inches				

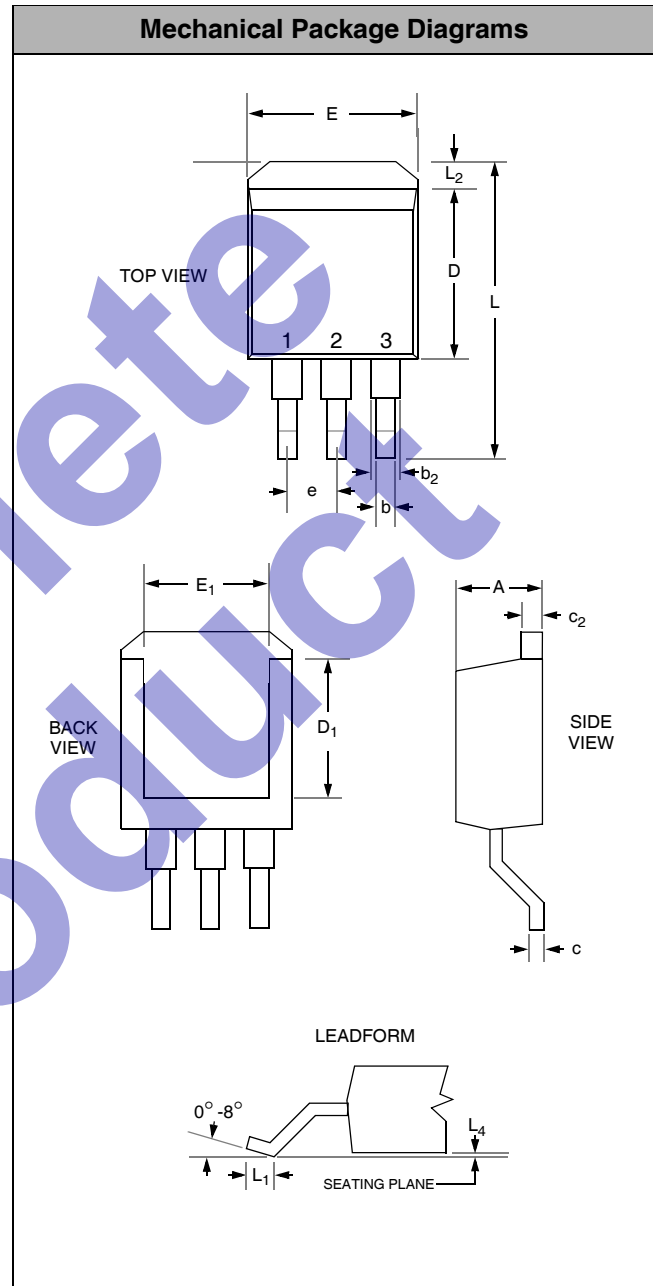

Package Dimensions for TO-263-3.

* This is an approximate amount which may vary.